

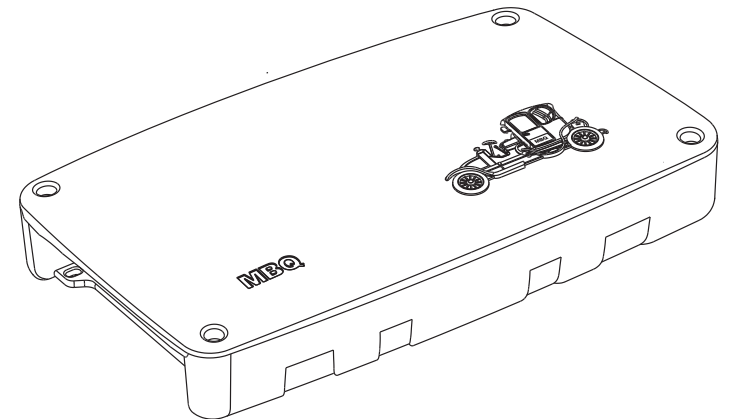

*Class D Power Amplifier*

**HD-1600D**

**HD-450D**



**USER MANUAL**

## INTRODUCTION

Professional installation by a dealer is highly recommended! Otherwise, the performance of your new gear may not be satisfactory. In the event that you decide to do your own installation, please read and follow this manual very carefully.

Failure to do so may compromise the integrity of this product, your automobile, and possibly void the product warranty.

Amplifiers are generally mounted in the hatch/trunk area of a car or SUV, and under or behind the seat of most pickup trucks. Select a location that will provide adequate ventilation for the amplifier.

Avoid mounting the amplifier with the fins facing down. The fins should be facing up, either vertically or horizontally. Secure the amplifier with the screws provided.

## FEATURES - CLASS AB AMPLIFIER

Before securing the amplifier, inspect the mounting location carefully to ensure that you do not drill into or damage any electrical, hydraulic, fluid or fuel lines.

## DESIGN FEATURES

- High quality SMD components, high accurate resistors and capacitors
- Double side FR-4 PCB
- Full MOSFET power circuit design
- Super noise rejection circuit
- Adjustable High pass, Low pass
- Overload, shortcircuit, thermal, low voltage protection
- RoHS, E-mark certification

## SPECIFICATIONS

Model	HD-1600D	HD-480D
Power Output @ 4Ω	370W X 1CH	80W X 4CH
Power Output @ 2Ω	600W X 1CH	120W X 4CH
Power Output @ 1Ω	—	—
Power Output @ 4Ω Bridged	—	260W X 2CH
Total Harmonic Distortion	0.06%	0.06%
S/N Ratio (A WTG) Ref 1W at 4Ω	96dB	96dB
Gain Range	0.2V-4V	0.2V-5V
Crossover Range	High 15Hz-55Hz Low 30Hz-250Hz	High 120Hz-3KHz Low 50Hz-250Hz
Frequency Range	20Hz-22KHz	20Hz-22KHz
Bass Boost	+12dB	+12dB
Demension(DxWxH)	280x160x51mm	280x160x51mm

## TROUBLE SHOOTING

MALFUNCTION	SOLUTION
Power LED off	Check connetions both at amplifier and at other ends Check plus and minus battery cables Check all fuses on amplifier Check remote voltage
No Output (Power LED on)	Check volume control on the source unit Check GAIN regulator on amplifier Check RCA cables and connections Check speaker cables and connetions
One Channel has as no function	Check RCA connections of this channel Check speaker connetion of this channel Balance regulator of source unit do not set in middle Speaker of this channel is damaged
Amplifier switches on and off	Check chasis ground connection with amplifier Check cable terminals and battery terminals Low voltage from battery Check the connection of the remote wire
Distorted Output	Source unit gain set too high Amplifier gain set too high Speaker(s) blown
No Output (Protect LED on)	Speaker is short circuit or damaged Amplifier is over temperature Amplifier is over loaded Battery is low voltage

# HD-480D WIRING DIAGRAM

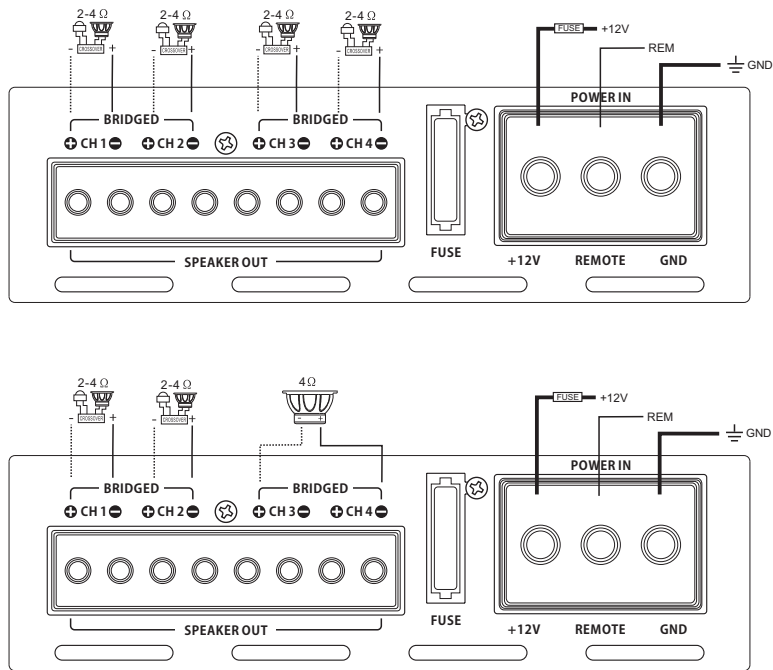

# DIAGRAM of 1 Channel Class D Power Amplifier HD-1600D

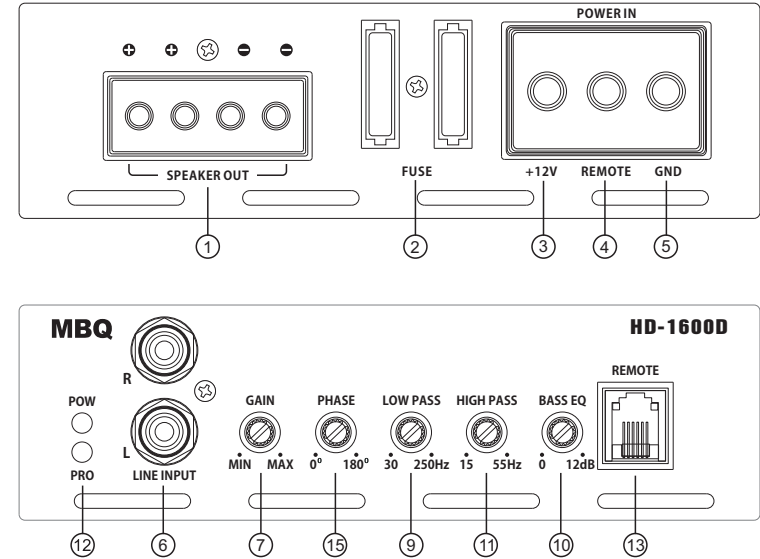

# DIAGRAM of 4 Channel Class D Power Amplifier HD-480D

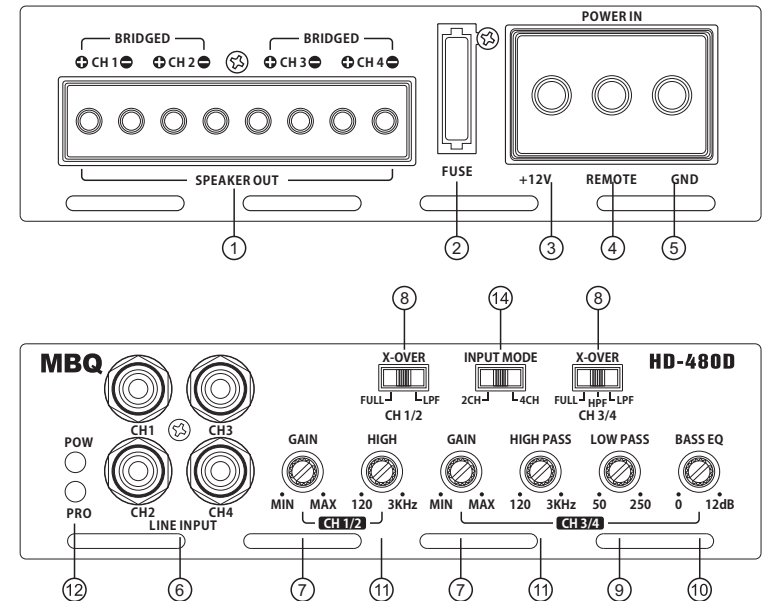

# TYPICAL POWER WIRING FOR ALL MODELS

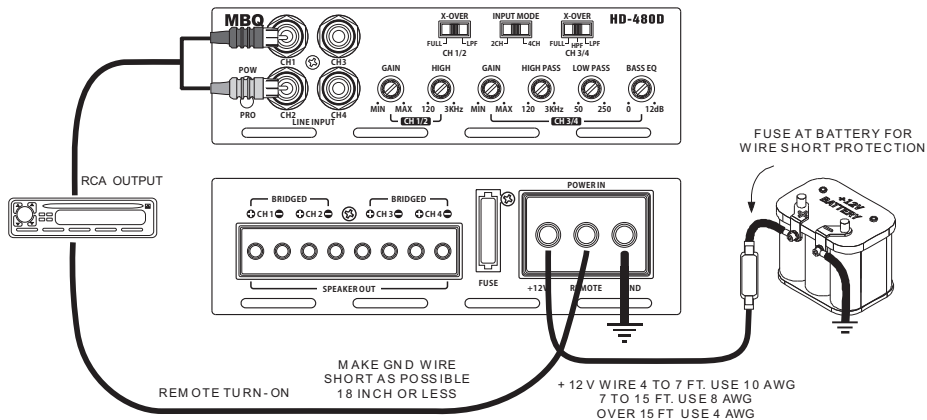

## FUNCTIONS

### 1. SPEAKER Output Terminals

This specially tooled solderless terminal block is designed to accommodate up to 10-gauge speaker wire. Please refer to the wiring diagrams in this manual and be sure to observe speaker polarity and impedance throughout the system.

### 2. FUSE(S)

For convenience, most auto sound amplifiers utilize common automotive ATC type fuses. For continued protection in the event that a fuse blows, replace the fuse only with the same value. CAUTION: These power fuses on the amplifier chassis are for protecting the amp against overdrive. To protect the vehicles electrical system, an additional fuse should be used within 18-inches of the battery on the 12V+ cable.

**HD-1600D 40A x 1 HD-480D 30A x 2**

### 3. BATT+ (Power Input Connection)

This solderless terminal is the main power input for the amplifier and must be connected directly to the 12-volt Positive (+) terminal of the car battery. The terminal can accept up to 4-gauge wire.

### 4. REMOTE (Remote Input Connection)

This amplifiers can be turned on by applying 12 volts to this terminal.

### 5. GND (Ground Input Connection)

A good quality ground is required for your amplifier to operate at peak performance. A short length of cable with the same gauge as the Power cable should be used to attach the Ground terminal directly to the chassis of the vehicle. Make sure that all of the paint is sanded or scraped away to ensure a good ground connection.

### 6. Line INPUT (RCA) Jacks

These RCA style input jacks are for use with source units that have RCA line level outputs. A source unit with a minimum output of 500mV is required for proper operation. However, this input will accept levels up to 6Vrms.

### 7. GAIN Control

This control is used to match the input sensitivity of the amplifier to the particular source unit that you are Using.

### 8. X-OVER Switch for LPF/FLAT/HPF

Activates the built-in electronic crossover network. Works in conjunction with the LPF and HPF adjustable controls.

### 9. LPF (Low Pass Filter) Control

This control is continuously adjustable from 30Hz through 150Hz at 12dB per octave.

### 10. BASS EQ Switch for 0dB/9dB/18dB

This equalization circuit is used to enhance the low frequency response of the Vehicles interior. Selectable to 0dB (flat) or 9dB to 18dB of boost centered at 40Hz, the BASS EQ switch can be selected to meet your own personal tastes.

### 11. HPF (High Pass Filter) Control

This control is continuously adjustable from 10Hz through 1.2KHz at 9dB per octave.

## FUNCTIONS

### 12. POWER/PROTECT Indicator

The clear LED lights Blue: when the power is on and the amplifier is wired correctly.

The clear LED lights Red: constantly when the built-in protection circuitry is activated, Red indicates a problem with the system in relation to the amplifier.

### 13. REMOTE (Remote Gain Input Connection)

This is the input port for the wired Remote Gain control (included). This allows up to 18dB of volume adjustment and controls the level of the subwoofer channel only.

### 14. Switch for CH2 or CH4

This control for the line input for CH2 or CH4.

### 15. PHASE Switch

This switchable control can be used to correct any phase or time delay effect in the system by bringing the low frequency from the rear of the vehicle to the front.

## HD-1600D WIRING DIAGRAM

